



# SmartVent

the expert's choice



## HEAT & ENERGY RECOVERY SYSTEMS





# Contents

Heat & Energy Recovery Systems	4-5
System Selection Guide	6
System Comparison Table	7
Systems:	
<b>Synergy3</b>	<b>8</b>
<b>Balance</b>	<b>8</b>
<b>Econiq</b>	<b>8</b>
<b>Tempra</b>	<b>9</b>
<b>Fresh</b>	<b>9</b>
<b>PureAir Room 260X</b>	<b>9</b>
SmartVent Ventilation Design Service	10
Specifications – Heat & Energy Recovery Systems	11
Positive Pressure Systems	12

## Why Ventilation?

Modern homes are more airtight than ever, improving energy efficiency but often trapping moisture and pollutants inside. Windows are often not sufficient or comfortable for effective ventilation, and heat pumps typically provide no fresh air at all. Poor ventilation can lead to mould growth, dust mites, VOC (Volatile Organic Compounds) buildup, and condensation, all of which impact indoor air quality and the health of your family and home.

### *Healthier Living*

Constant fresh air circulation improves comfort, health and well-being.

### *Moisture Control*

Helps prevent mould, dampness and condensation, making homes easier to heat.

### *Better Air Quality*

Reduces allergens, pollutants, and excess humidity.

### *Efficient Comfort*

Heat recovery systems help keep your home warm in winter and cool in summer by reusing energy, making your home more comfortable and efficient.



## Why SmartVent

SmartVent is a trusted name in home ventilation, backed by a family of international leaders in energy-efficient indoor air solutions. With over 40 years of expertise, SmartVent is the preferred choice for trade professionals: offering innovative, flexible, and forward-thinking systems designed for New Zealand homes.

### Industry Expertise

Recommended by electricians and HVAC contractors nationwide.

### Quiet Performance

A blend of fan technology, housing and system design helps deliver quieter performance.

### Advanced Controls

Controls are purpose-built for each system and selected to suit your home's needs.

### Flexible Solutions

Our systems are flexible, with a range of installation options even for challenging or compact spaces.

### Reliability

5-year warranty and high-quality components for long-term peace of mind.



## What We're Made Of

SmartVent systems are designed for effortless control and superior air filtration, ensuring a healthier and more comfortable home environment.

### Add-ons and System Components



#### Filters

SmartVent heat recovery systems have a range of filter options depending on the model, and we can help you choose the best solution.



#### Dew Point Control

Many SmartVent systems use real humidity levels and temperatures to provide the right air at the right time, so you don't even need to lift a finger.



#### Brushless EC fans

Most SmartVent systems use energy-efficient brushless EC fans for lower running costs.



#### Efficient Cores

With options up to 93% efficient, including both energy and heat recovery, we have a solution for every job.



#### Designed for you

Not every home is the same. At SmartVent we understand that and can help by tailoring a solution for you.

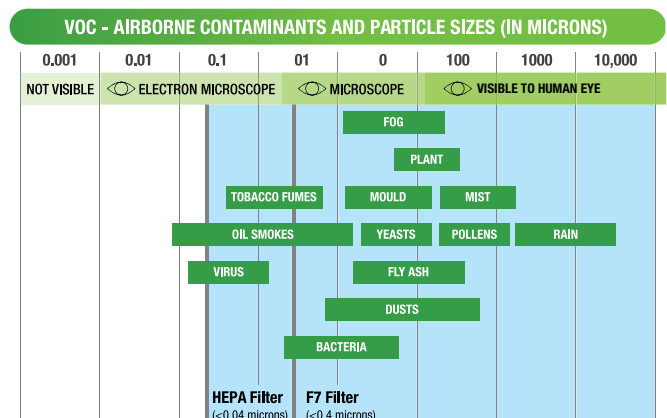

# HEAT & ENERGY RECOVERY SYSTEMS

**5**  
YEAR  
WARRANTY



**For those who want to maximise comfort.**

A heat recovery system brings fresh air into your home while helping keep it warm in winter and cool in summer. It works by capturing the heat (or coolness) from the stale air being removed, and transferring it to the fresh air coming in. This helps maintain a comfortable indoor temperature and reduces energy waste.

In colder months, it's especially important for your ventilation system to support the warmth in your home rather than undo it. The key to performance is the system's core efficiency — the better it is, the more heat it can recover.

In summer, many systems include a built-in bypass that brings in cooler outside air, helping your home stay comfortable without using extra energy.

 **Preserving indoor air temperature**

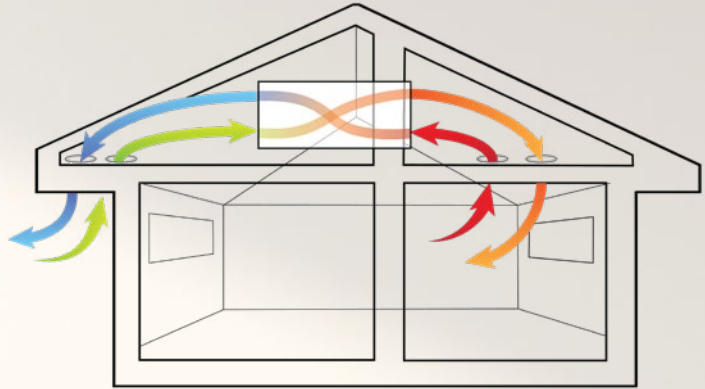

**Exhaust Air**

Moist, stale air forced out of the home

**Supply Air**

Tempered air enters the home

**Outside Air**

Fresh air drawn in from outside

**Return Air**

Moist, humid air is extracted from the home

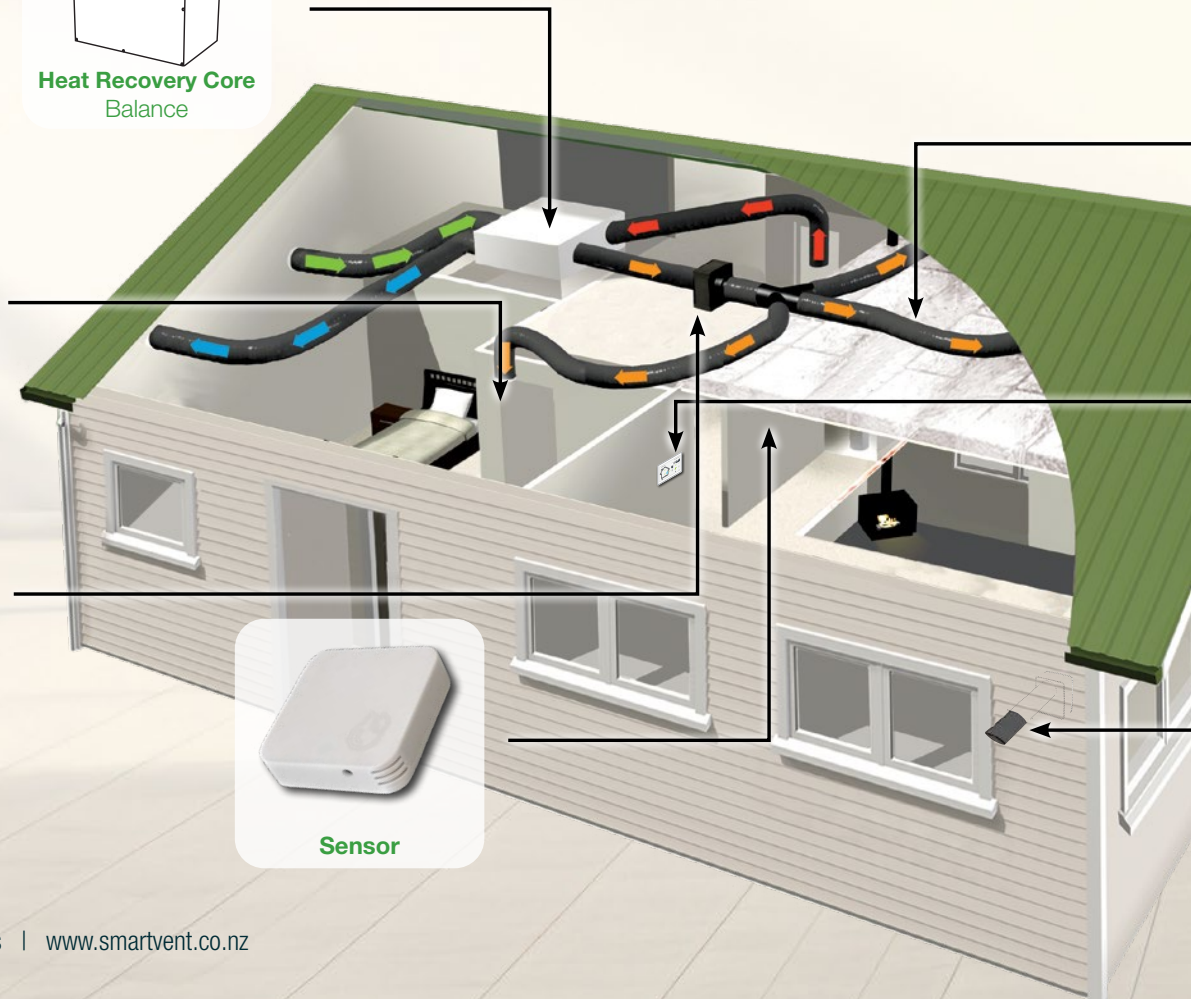
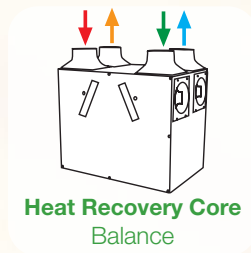
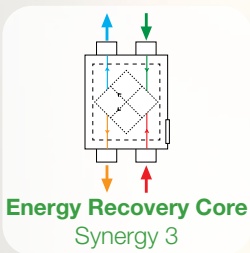



# Traditional Ventilation **vs** Heat Recovery

## Why heat recovery?

A heat recovery system does more than just ventilate your home—it also helps maintain a comfortable temperature. This means your heating or cooling system doesn't have to work as hard, which can **lower your power bills** throughout the year.

The following charts and graphs demonstrate how much of your heating bill you could save by installing a heat recovery system instead of a traditional ventilation system (Fig.1).

**Mechanical ventilation with heat recovery units (MVHR) offer additional energy savings above and beyond that of a typical ventilation system.**

*Assumptions: The savings shown here are based on potential heating cost savings when reheating air through a 90% efficient MVHR running continuously versus a direct air system to achieve 20°C+ year-round for an air volume based on 0.35ACH in a 150m<sup>2</sup> house with a 2.4m ceiling height using electric heat at 30 cents/kWh.*



**Acoustic Insulated Ducting**



**Full-Featured Controller and App Control**



**Compact Heat Exchanger**

**Cumulative Heating Cost Savings (Fig.1)**

North Island	2 Years	5 Years	10 Years
Auckland	\$ 1,268.28	\$ 3,170.69	\$ 6,341.38
Hamilton	\$ 1,348.54	\$ 3,371.34	\$ 6,742.68
Tauranga	\$ 1,348.54	\$ 3,371.34	\$ 6,742.68
Taupo	\$ 2,224.97	\$ 5,562.44	\$ 11,124.87
New Plymouth	\$ 1,750.61	\$ 4,376.53	\$ 8,753.06
Hawke's Bay	\$ 1,724.04	\$ 4,310.10	\$ 8,620.20
Palmerston North	\$ 1,952.94	\$ 4,882.35	\$ 9,764.69
Wellington	\$ 1,665.66	\$ 4,164.16	\$ 8,328.32

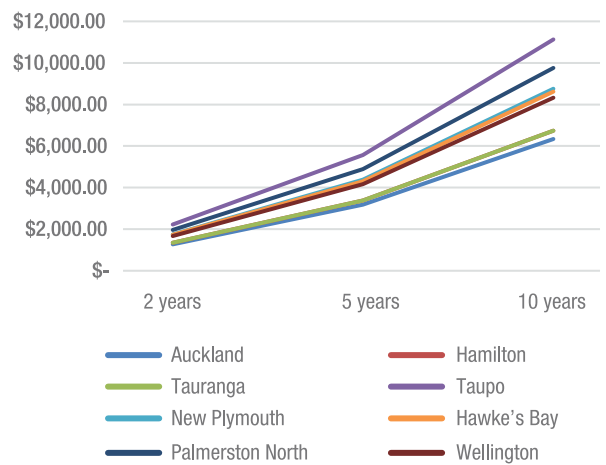



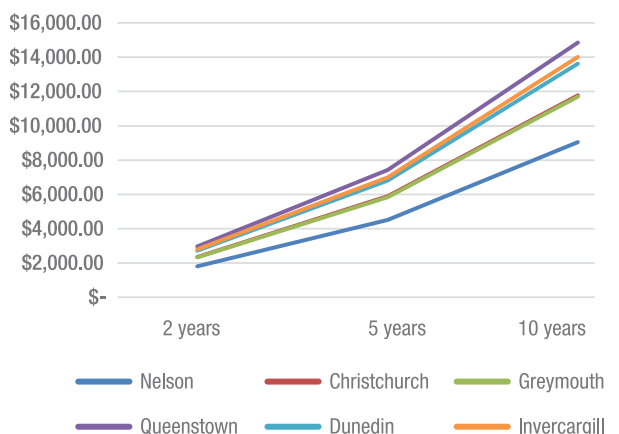



South Island	2 Years	5 Years	10 Years
Nelson	\$ 1,808.05	\$ 4,520.13	\$ 9,040.25
Christchurch	\$ 2,354.70	\$ 5,886.75	\$ 11,773.51
Greymouth	\$ 2,338.37	\$ 5,845.92	\$ 11,691.84
Queenstown	\$ 2,970.20	\$ 7,425.50	\$ 14,851.01
Dunedin	\$ 2,725.52	\$ 6,813.79	\$ 13,627.59
Invercargill	\$ 2,801.87	\$ 7,004.67	\$ 14,009.34

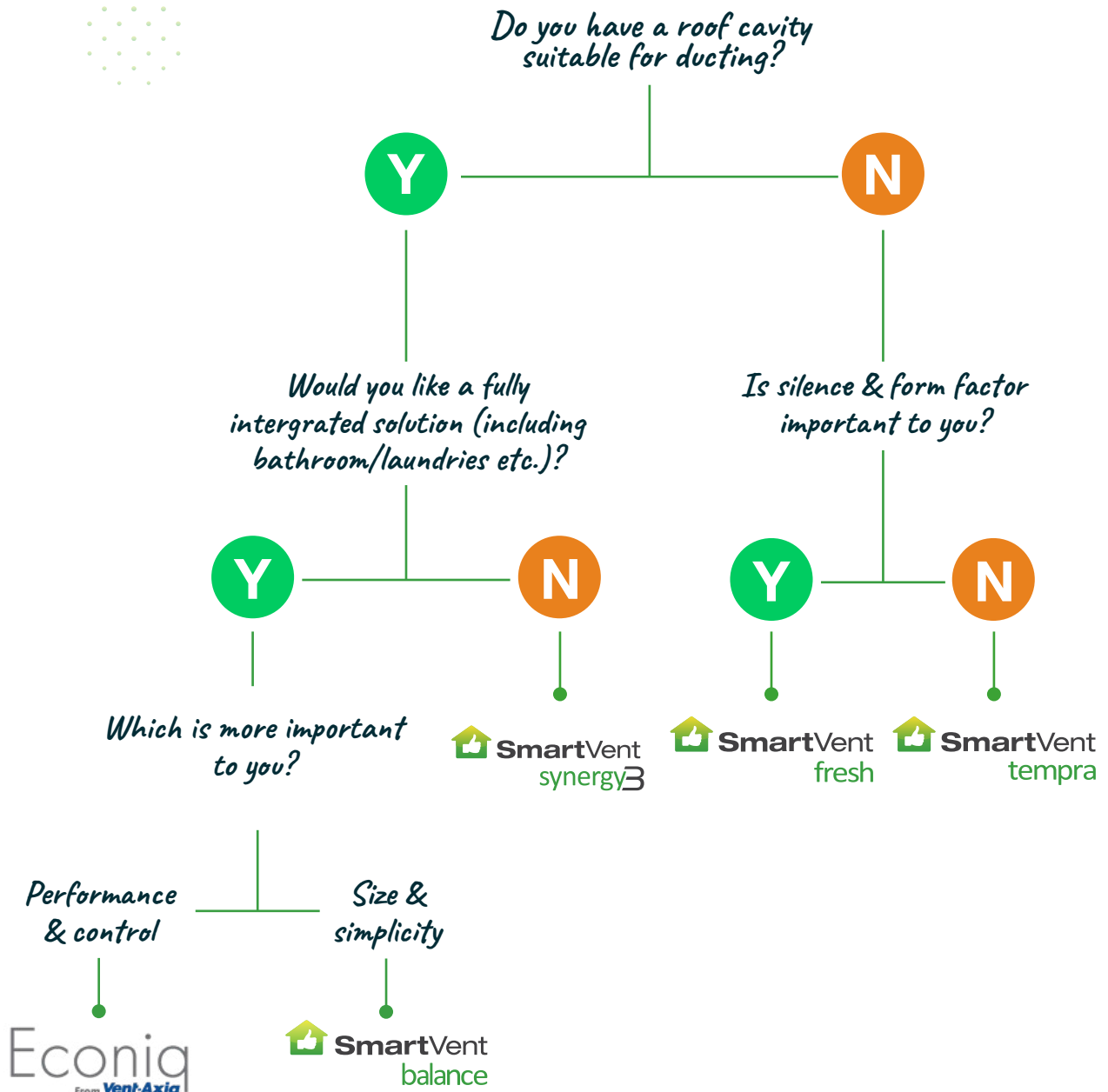

# System Selection Guide

All SmartVent Home Ventilation Systems will help provide a drier, healthier home, but there's more to it than that. Find the best solution for you:



System	Synergy3	Balance	Econiq	Fresh	Tempra
 <p><b>HEAT &amp; ENERGY RECOVERY SYSTEMS</b></p>	 <p>Build your own solution on a practical base with modern control and app. Choose the comfort features that matter most to you.</p>	 <p>Set and forget with this high-performance complete solution. Deliver both extract and supply in one package, designed to be hidden away.</p>	 <p>Our highest-performance home ventilation system with advanced automation and app control. Delivering an all-in-one ventilation solution.</p>	 <p><b>No roof cavity? No problem!</b> Supply and extract air through external walls with this system. Optional add-ons are available to provide additional system automation.</p>	 <p>A stand-alone, through-wall heat recovery system. Designed for single room &amp; wet room ventilation.</p>
<b>Supply Rooms</b> (Fresh Air In)	3 to 6	3 to 6	3 to 8	Up to 16 units total	1 per unit
<b>Extraction Rooms</b> (Stale Air Out)	1 to 2	1 to 3	1 to 4	Up to 16 units total	1 per unit
<b>Moisture Control</b>	Dry rooms	Wet & dry rooms	Wet & dry rooms	Dry rooms	Wet & dry rooms
<b>Heat Recovery Efficiency</b>	Up to 75%	Up to 90%	Up to 93%	Up to 82%	Up to 80%
<b>Heat Recovery Locations</b>	Dry rooms	Wet and dry rooms	Wet and dry rooms	Dry rooms	Wet & dry rooms
<b>Cheaper to Run</b> (EC Fan)	AC fan	✓	✓	✓	N/A
<b>Quieter Design</b>	✓ (Acoustic duct)	✓ (Low noise fan)	✓ (Low noise fan)	✓ (Low noise fan)	N/A
<b>Roof Cavity Required</b>	✓	Wall or roof mounted	Wall or roof mounted	Installed through-wall	Installed through-wall
<b>Standard Filter</b> (Upgrade available)	G3 (+ F7, kit dependent)	G3 (+ F7, kit dependent)	G4 (+Upgrade option)	Washable dust filter	Washable insect screen
<b>Comfort Add-Ons</b>					
<b>Flexi Air Source</b> Chooses the best air source for the home	Optional	N/A (Core bypass built-in)	N/A (Core bypass built-in)	Programmable direction built-in	N/A
<b>Heat Transfer</b> Shares the warmth from the lounge to the bedrooms	Optional	Separated	Separated	Separated	Separated
<b>Air Tempering</b> Uses indoor air to temper entering air or an electric heater	Optional Tempering Heater (up to 75% energy recovery built in)	Includes up to 90% heat recovery	Includes up to 93% heat recovery	Includes up to 82% heat recovery	Includes up to 80% heat recovery
<b>Core Bypass</b> Allows direct air when conditions are comfortable	N/A	✓	✓	✓ (+One-way operation)	N/A
<b>Controls &amp; Sensors</b>					
<b>Controls</b>	6.8" Colour Touchscreen	Wall Controller	Wall Controller	Wall Controller (Optional)	Pull Cord
<b>App Control</b>	✓	N/A	✓	✓	N/A
<b>Controller Ease of Use</b>	Easy	Intermediate	Advanced	Advanced	Easy
<b>Functionality</b>	Enhanced	Intermediate	Enhanced	Enhanced	Basic
<b>Humidity and Temperature Sensing</b>	✓ x4	✓ (Built-in)	✓ (+Expandable)	✓ (Optional)	N/A
<b>Rental Lock</b>	N/A	✓	N/A	N/A	N/A
<b>Scheduling</b>	Weekly	Daily	Weekly	Weekly	N/A

\*Designed solutions may exceed these numbers.

# Centralised Heat & Energy Recovery Solutions

## Comfortable and efficient home ventilation

**Heat recovery cores** have the added benefit of being suitable for wet zones and can be used to provide extraction to kitchens, bathrooms and laundries as well as supplying throughout your home. **Energy recovery cores** provide efficient performance and a small amount of moisture exchange but cannot be used for extraction from wet rooms. They are beneficial when you live in a particularly dry or humidity-controlled environment. Both systems achieve their best performance when installed within the thermal envelope.

Econiq  
From Vent-Axia

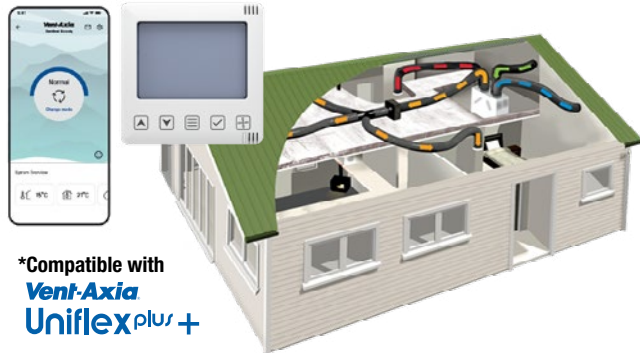

\*Compatible with  
Vent-Axia  
Uniflex plus +

Our premium heat recovery solution with app control, up to **93% heat recovery**, incredibly quiet operation, built-in summer bypass, humidity sensing and an economical EC fan. The airtight construction includes easy change filters, additional unit insulation, and a heat recovery core providing both fresh air supply and bathroom extraction, efficiently. Plus, you can add additional remote sensing locations to your custom design.

### BEST FOR

Larger or custom homes and particularly those paying attention to **energy efficiency, airtightness and comfort** while wanting a fully integrated, balanced fresh air and extraction solution with expandable, **advanced controls**.

### SUPPLY & EXTRACT ROOMS #

**MEDIUM-LARGE** (223m<sup>3</sup>/hr, 100-400m<sup>2</sup>) **3-5 supply, 1-2+ exhaust** (Econiq S)

**EXTRA LARGE** (395m<sup>3</sup>/hr, 150-500m<sup>2</sup>) **4-8 supply, 2-4+ exhaust** (Econiq M)

*NOTE: Larger or more complex layouts available by request.*

SmartVent  
balance

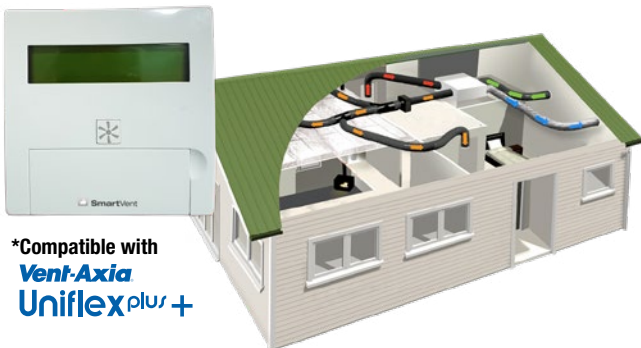

\*Compatible with  
Vent-Axia  
Uniflex plus +

A well-rounded heat recovery solution with set and forget controls, up to **90% heat recovery**, built-in summer bypass, humidity sensing and an economical EC fan. Its compact form allows installation through ceiling hatches or in cupboards and wardrobes, requiring minimal space while still including easy change filters. The heat recovery core allows for both fresh air supply and bathroom extraction, efficiently.

### BEST FOR

Most homes, but particularly those wanting **no-nonsense controls, good performance, efficiency and comfort** in a fully integrated, balanced fresh air and extraction solution. Great option for **townhouses and apartments** wanting central ventilation.

### SUPPLY & EXTRACT ROOMS #

**MEDIUM** (223m<sup>3</sup>/hr, 50-250m<sup>2</sup>) **3-4 supply, 1-2 exhaust** (BAL225)

**LARGE** (395m<sup>3</sup>/hr, 100-450m<sup>2</sup>) **5-6 supply, 2-3 exhaust** (BAL405)

*NOTE: Larger or more complex layouts available by request.*

SmartVent  
synergy3



A flexible, energy-efficient solution with app control, four sensing locations, and an advanced Touchscreen. Up to **75% energy recovery** and the option to integrate heat transfer, multiple air sources and additional heaters.

### BEST FOR

Homes with a fireplace, an existing/alternative extraction system or where a shorter height is required. Not suitable for bathroom extraction.

### SUPPLY & EXTRACT ROOMS #

**SMALL** (137m<sup>3</sup>/hr, 50-150m<sup>2</sup>) **3-4 supply, 1-2 return** (SYN1015AD)

**MEDIUM** (216m<sup>3</sup>/hr, 75-250m<sup>2</sup>) **3-5 supply, 1-2 return** (SYN2025AD)

**LARGE** (324m<sup>3</sup>/hr, 120-350m<sup>2</sup>) **3-6 supply, 1-2 return** (SYN3035AD)

### ADD-ONS

Flexi Air Source	Heat Transfer	Tempering Heater Small (1kW)*	Tempering Heater Large (2kW)*	Through-wall Grille

*\*Sizing is indicative only and depends on house layout and installation, max house size based on 0.35ACH@2.45m ceiling height and 150Pa for a straightforward single story install. We recommend not sizing at max if boost capacity is desired. Contact SmartVent for design advice if more outlets, extracts/returns or complex duct installs are required.*

*\*Compatible with our specialised small ducting solution Uniflex+ for more robust installations in confined spaces. Uniflex+ installation should be within the thermal envelope.*

# Single Room Solutions

Smarter ventilation options for complex homes

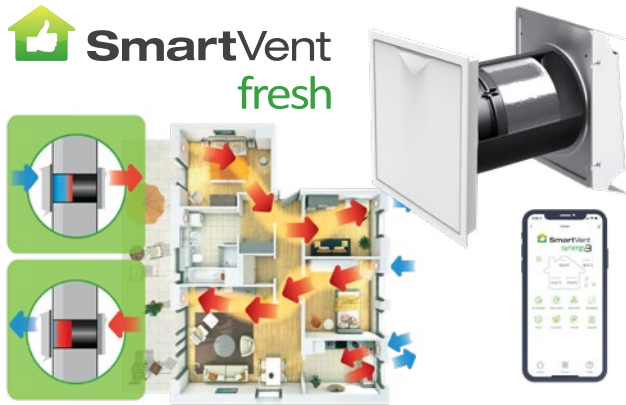

## ADD-ONS

Wireless e16 Wall Controller	Indoor CO2 Sensor	Outdoor Humidity & Temperature Sensor	Indoor Humidity & Temperature Sensor

A quiet **through-wall** ventilation system with **82%** heat recovery that connects to a network of other units and offers several control options, including app control. It uses very quiet and energy-efficient fans.

### BEST FOR

Custom and complex homes where space is at a premium. Perfect for bedrooms and living areas where low noise and clean design are important, while still delivering great comfort, smart control, and energy efficiency.

### IDEAL HOME TYPE

Townhouses, apartments, homes with skillion or cathedral ceilings, tiny homes, and sleepouts.

**SUPPLY ROOMS** 1 per bedroom, 1-2 per living space

**COVERAGE\*** Up to 33m<sup>2</sup>

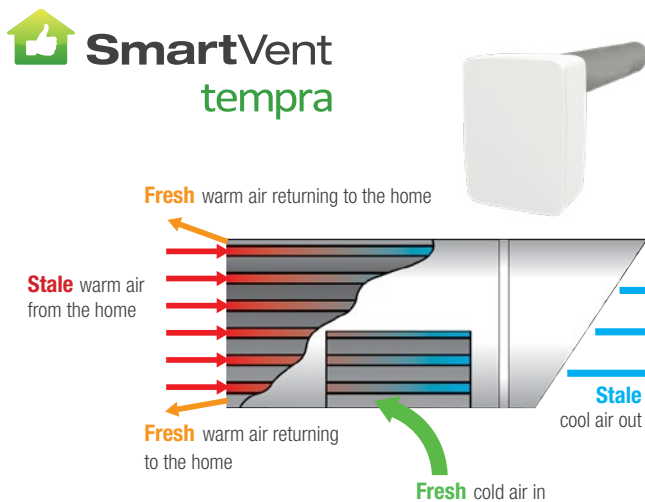

A **stand-alone, through-wall** ventilation system with **80%** heat recovery. Designed for bathrooms and living spaces. It has a small wall penetration and easy-to-use controls, making it simple to install and operate.

### BEST FOR

Bathrooms, garage conversions, and shared spaces where consistent balanced airflow matters most.

### IDEAL HOME TYPE

Bathrooms, garage conversions, communal areas, and relocatable or multipurpose spaces.

**SUPPLY ROOMS** 1 per room

**EXTRACT ROOMS** 1 per room (wet room compatible)

**COVERAGE\*** Up to 37m<sup>2</sup>

## Vent-Axia PureAir Room 260X



### PURIFY YOUR INDOOR AIR FOR A HEALTHIER HOME ENVIRONMENT

An in-room air purifier—perfect when opening windows isn't an option\*.

*\*Please note: This unit is not a dehumidifier.*

### BEST FOR

Reducing dust, mould spores, bacteria, and viruses in homes.

### IDEAL SPACE TYPE

Living rooms, dining areas, bedrooms, nurseries, and home offices.

**SUPPLY ROOMS** 1 per room (portable)

**COVERAGE\*** 30m<sup>2</sup>

\*Room size varies by occupancy, usage type and compliance requirements. Sizes given here based on 0.35ACH and 2.45m stud height. For high loads or occupancy additional units may be required.

# Ventilation Design Service

## How can we help?

Our design service lets you use our team's ventilation expertise to help choose the right system for your complex project or new build, specifically designed to suit your needs and relevant compliance.

**Just fill out our design form, and we'll send you a full system design and parts list tailored to your home or project.**



## Who do we help?

### Complex Design

Some homes have tricky layouts or limited space for ducting. Complex designs are typically found in architectural homes, cathedral/skillion roofs, properties with a small or no roof cavity, multi-storey buildings, and high-end homes. Our experts can help design a system that works.

### Compliance

The SmartVent ventilation design service offers full support for ensuring ventilation building code compliance and improving acoustic design including G4, healthy homes, Homestar, and background or aircraft noise areas.

### High End Homes

High end and passive homes with a focus on energy efficiency. Our design service can help create proper air channels and ensure that the property is getting the required air changes per hour.

### Heat Pump Integrations

Give us your heat pump design and we can provide a heat recovery overlay and parts list. This lets you get the best of both worlds; fresh air at a comfortable temperature, without breaking the bank every time you turn it on.

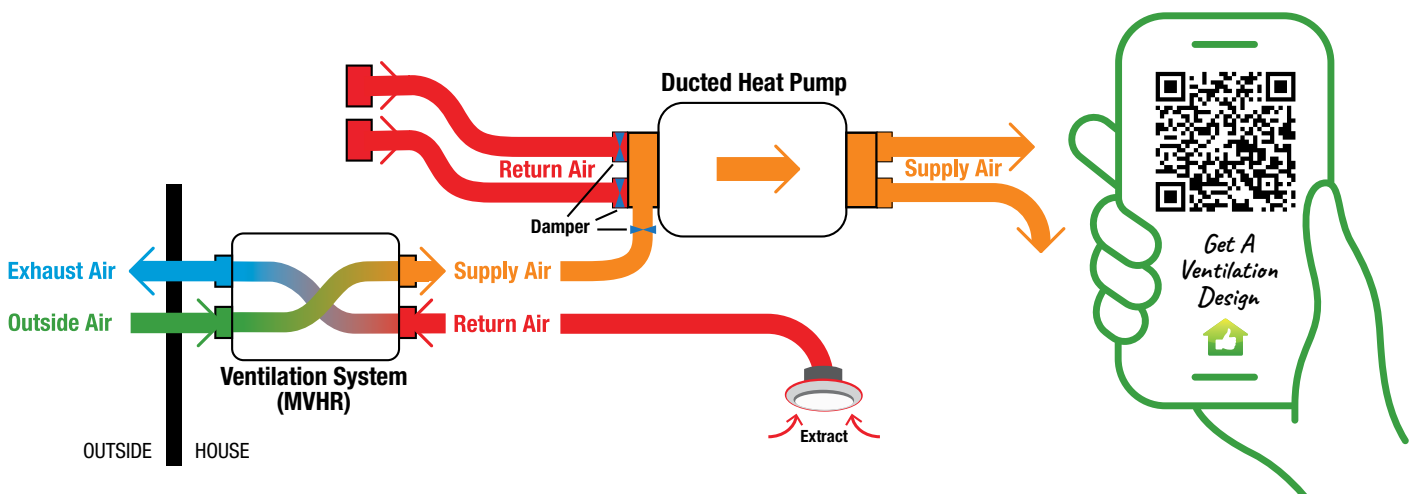

Systems	Synergy3			Balance		Econiq	
Coverage	Up to 110m <sup>2</sup>	Up to 135m <sup>2</sup>	Up to 250m <sup>2</sup>	Up to 150m <sup>2</sup>	Up to 250m <sup>2</sup>	Up to 250m <sup>2</sup>	Up to 350m <sup>2</sup>
Specifications	SYN1015AD	SYN2025AD	SYN3035AD	BAL225	BAL405	Econiq S	Econiq M
Fan Type	AC Centrifugal			EC Centrifugal		EC Centrifugal	
Max. Fan Cores	2			-		-	
Spigot Size	150mm			125mm	150mm	125mm	200mm
Fan Speeds	3			10		4 (Programmable)	
Max. Air Flow per Fan @ 0 Pa	77 l/s, 277 m <sup>3</sup> /hr	97 l/s, 350 m <sup>3</sup> /hr	130 l/s, 468 m <sup>3</sup> /hr	76 l/s, 275 m <sup>3</sup> /hr	136 l/s, 490 m <sup>3</sup> /hr	177 l/s, 421 m <sup>3</sup> /hr	166 l/s, 600 m <sup>3</sup> /hr
Max. Air Flow per Fan @ 150 Pa	38 l/s, 137 m <sup>3</sup> /hr	60 l/s, 216 m <sup>3</sup> /hr	90 l/s, 324 m <sup>3</sup> /hr	62 l/s, 223m <sup>3</sup> /hr	110 l/s, 395 m <sup>3</sup> /hr	97 l/s, 349 m <sup>3</sup> /hr	125 l/s, 450 m <sup>3</sup> /hr
Max. Static Pressure per Fan	238 Pa	285 Pa	354 Pa	380 Pa	600 Pa	700 Pa	680 Pa
Power Supply	230–240V AC 50 Hz			220–240V AC 50 Hz		220–240V AC 50 Hz	
Total Input Power	120W	178W	280W	128W	173W	166W	206W
Current (A)	0.46A	0.7A	1.1A	0.58A	0.79A	0.76A	0.94A
Operating Temp	-10°C to 40°C			-20°C to 45°C		-20°C to 40°C	
Sound Level	31.5 dB(A)	34 dB(A)	37 dB(A)	39 dB(A)		43 dB(A)	38 dB(A)

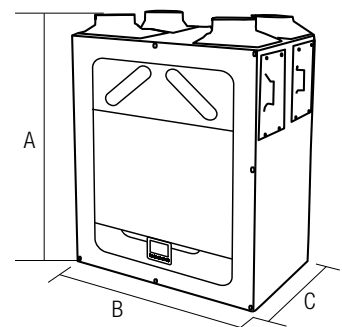
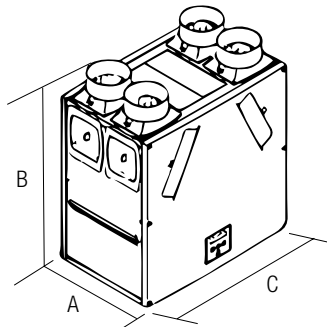
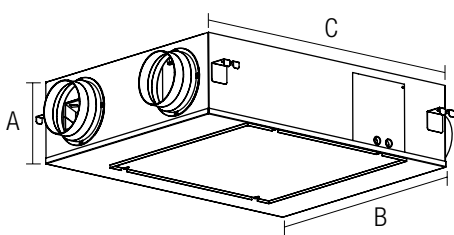

Synergy3 Core Dimensions (mm)	A	B	C
SYN1015AD	230	690	860
SYN2025AD	230	710	930
SYN3035AD	240	820	1070

Balance Core Dimensions (mm)	A	B	C
BAL225	285	650	550
BAL405	524	745	776

Econiq Core Dimensions (mm)	A	B	C
Econiq S	823	660	443
Econiq M	931	728	608

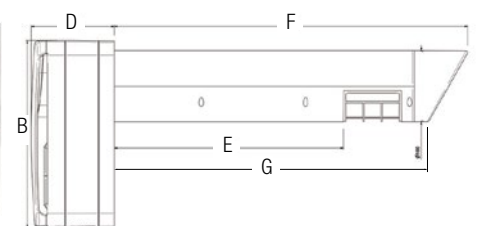
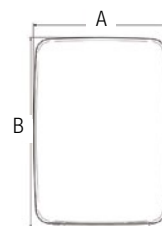
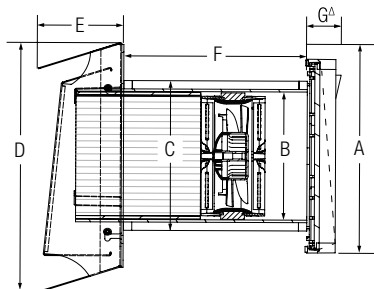

Fresh Dimensions (mm)	A	B	C	D	E	F	G
Standard	270	Ø160	Ø180	276	80	≥140	44

Tempra Dimensions (mm)	A	B	C	D	E	F	G
Standard Tube	190	266	262	117	321	496	450
Long Tube	190	266	262	117	461	636	590

Specification	Trickle (25%)	Medium (40%)	High (70%)	Boost (100%)
Efficiency	82%	72%	68%	60%
Extract/Heat Recovery (Pair)*	5.5 l/s (20m <sup>3</sup> /hr)	7.2 l/s (26m <sup>3</sup> /hr)	11.1 l/s (40m <sup>3</sup> /hr)	16.1 l/s (58m <sup>3</sup> /hr)
Power (Pair+Controller)	2.6W	3.5W	5.3W	10.1W
Heat Recovery (Single)*	2.8 l/s (10m <sup>3</sup> /hr)	3.6 l/s (10m <sup>3</sup> /hr)	5.5 l/s (20m <sup>3</sup> /hr)	8 l/s (28m <sup>3</sup> /hr)
Power (Single)	1.3W	1.75W	5.3W	10.1W
Sound	12dB(A)	24dB(A)	30dB(A)	37dB(A)

Specification	Trickle – Low	Trickle – High	Boost
Free Air Performance	6 l/s	9 l/s	15 l/s
Power	3.2W	5.7W	26.6W
Sound	27.3 dB(A)	35.9 dB(A)	48.8 dB(A)



## Home Ventilation Systems



***Ask what we can do for you***

General enquiries ph: 0800 140 150

[www.smartvent.co.nz](http://www.smartvent.co.nz) | [hello@smartvent.co.nz](mailto:hello@smartvent.co.nz)



The team at SmartVent is committed to our sustainability goals including reusing all packaging bearing this mark  please ask your installer for more information on this exciting initiative.

Specifications are subject to change without notice

By **Simx** | PUB1879 2603